

KIT CENTINA  
SIDE CURTAIN KIT



B-lift



**Autocar**

Autocar





# Indice

Index



<b>Centina B-lift</b> B-lift bodywork	<b>01</b>
<b>Centina certificata XL</b> Kit certified XL	<b>02</b>
<b>B-lift anteriore</b> B-lift frontwall	<b>03</b>
<b>B-lift tetto</b> B-lift roof	<b>05</b>
<b>B-lift piantane</b> B-lift corner pillars	<b>07</b>
<b>Portale posteriore</b> Rear frame	<b>11</b>
<b>Grafica personalizzata</b> Customized graphic	<b>13</b>
<b>Piantoni MAXI</b> MAXI pillars	<b>21</b>
<b>B-lift parametrico</b> B-lift height references	<b>23</b>
<b>Componenti</b> Components	<b>25</b>





# CENTINA B-LIFT

## B-LIFT BODYWORK



### CENTINA COMPLETA IN KIT

B-LIFT è un sistema completo disegnato da AUTOCAR per allestire completamente un veicolo telonato medio-pesante (7,5 - 26 ton).

Il B-LIFT è un sistema universale, in grado di soddisfare tutte le esigenze dimensionali all'interno di questo range di peso, dovendo scegliere solo la lunghezza del tetto. Questo offre al carrozziere la possibilità di avere il kit a magazzino pronto all'uso, senza necessità di doverlo ordinare a misura.

B-LIFT è disponibile sia con dispositivo alzabassa per sollevamento del tetto nelle operazioni di carico/scarico sia con dispositivo MULTIPUNTO, con altezza variabile.

### COMPLETE SIDE CURTAIN KIT

B-LIFT is a complete side curtain system designed by AUTOCAR to fully equip a curtain body of medium-heavy weight (7,5 - 26 ton).

B-LIFT kit is a universal system, that can fit every dimension within the above-mentioned weight range. This allows the bodybuilder to have our kit available on stock, without having to order it as a customized product.

B-LIFT is available both with roof lifting mechanism to ease loading and unloading operations as in the MULTI-HEIGHT version, with adjustable heights.

# CENTINA CERTIFICATA EN DIN 12642 CODE XL

## KIT CERTIFIED EN DIN 12642 CODE XL

Il kit centina B-LIFT è composto da parete anteriore in alluminio, completa di profilo di chiusura superiore regolabile, tetto MAGNUM TOPLINE2 scorrevole, porte posteriori MAGNA2 in alluminio a 3 profili rinforzati, piantoni centrali MAXI3 versione side curtain oppure MAXI DUO a 2 leve versione spondata, piantane anteriori e posteriori con sistema di sollevamento idraulico a pompa individuale.

A completamento dell'assemblaggio vengono fornite anche le piastre di fissaggio e di collegamento del tetto, che permettono un sollevamento simmetrico o unilaterale.

AUTOCAR fornisce tutta la viteria e le istruzioni necessarie per un montaggio facile e veloce.

“ La centina B-LIFT dispone della certificazione EN DIN 12642 CODE XL per la sicurezza del carico stradale, avendo superato i test con ottimo risultato, sia nella versione SPONDATA sia nella versione SIDE CURTAIN. ”

Our bodywork curtain kit B-LIFT is composed of aluminium frontwall, MAGNUM TOPLINE2 sliding roof, MAGNA2 rear doors with 3 reinforced aluminum panels, sliding pillars MAXI3 for curtainsider or MAXI DUO pillars (2 levers) in case of sideboards, front and rear corner pillars with manual hydraulic lifting system.

We also supply roof connection brackets, that allow to lift the roof symmetrically or unilaterally. We provide all the pins, screws and nuts as well as complete instruction manuals in order to assure an easy and fast assembly.

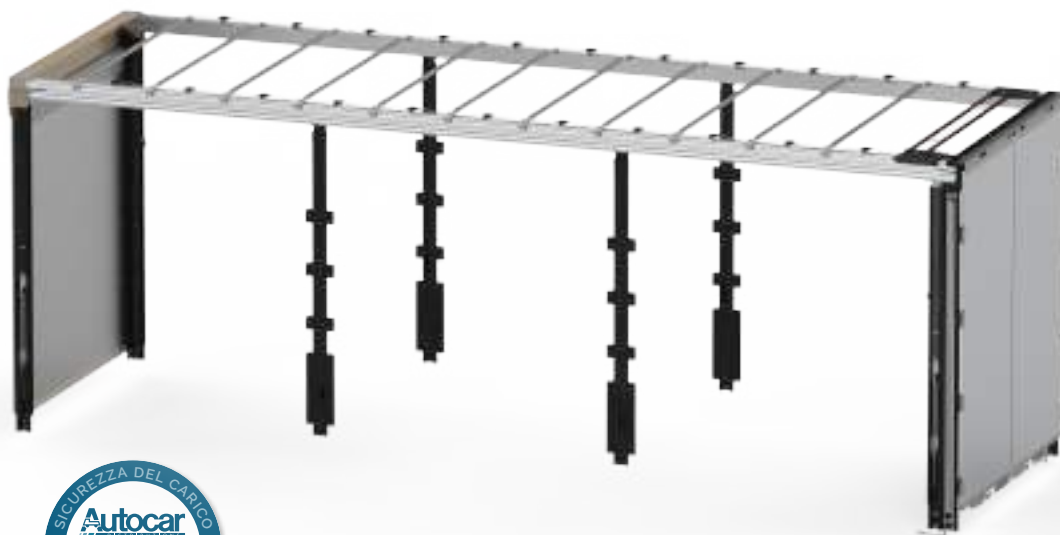

“ B-LIFT bodywork curtain kit for both curtainsider and bodies with sideboards is certified EN DIN 12642 Code XL for loads safety, since it has passed tests with great results. ”



# B-LIFT ANTERIORE

## PARETE ANTERIORE IN ALLUMINIO

Abbiamo curato fino all'ultimo particolare la funzionalità della carrozzeria. La parete anteriore si compone con i nostri robusti profili da 420 mm ed è completa di profilo di chiusura superiore regolabile.

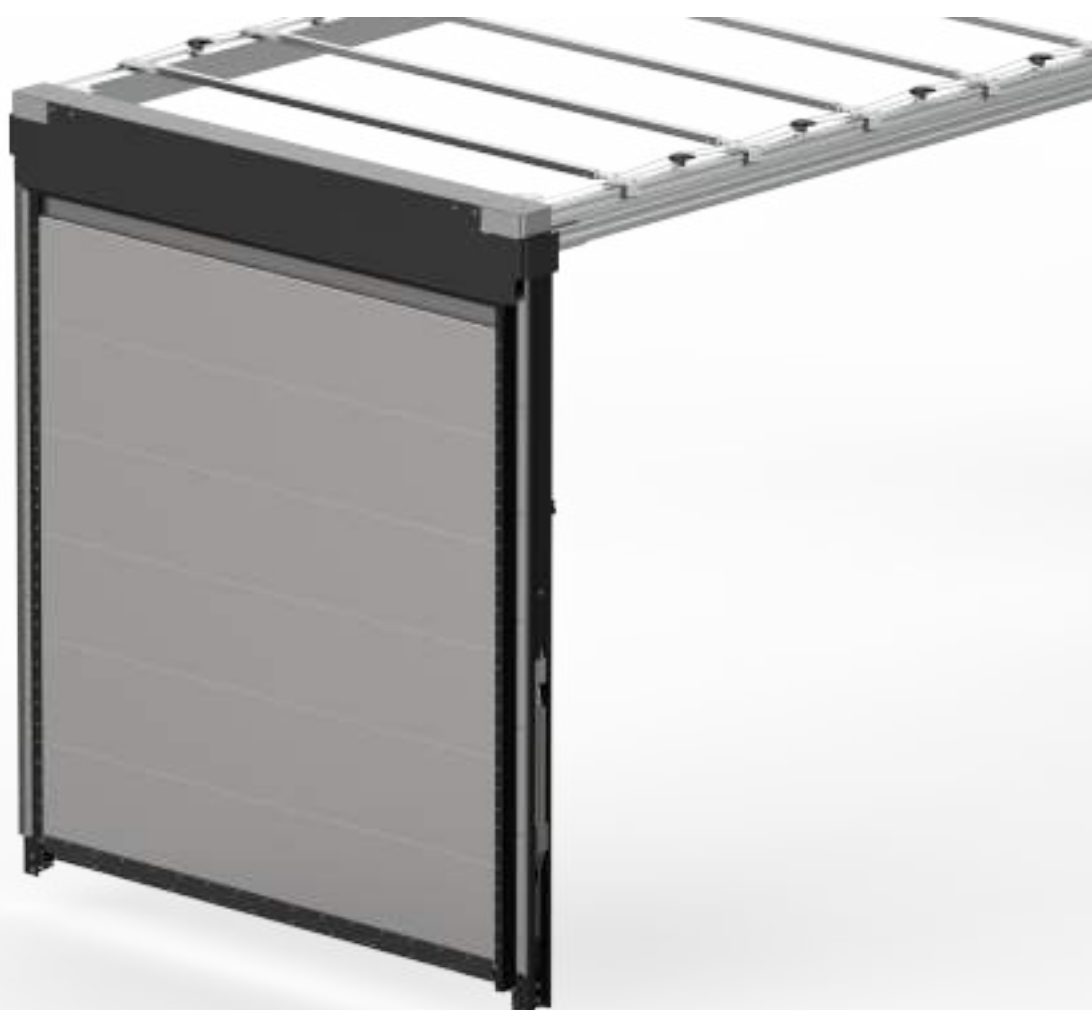



# B-LIFT FRONTWALL

## ALUMINUM FRONTWALL

We have especially taken care of functionality. Our frontwall is composed of strong 420 mm aluminum profiles and adjustable end upper profile.

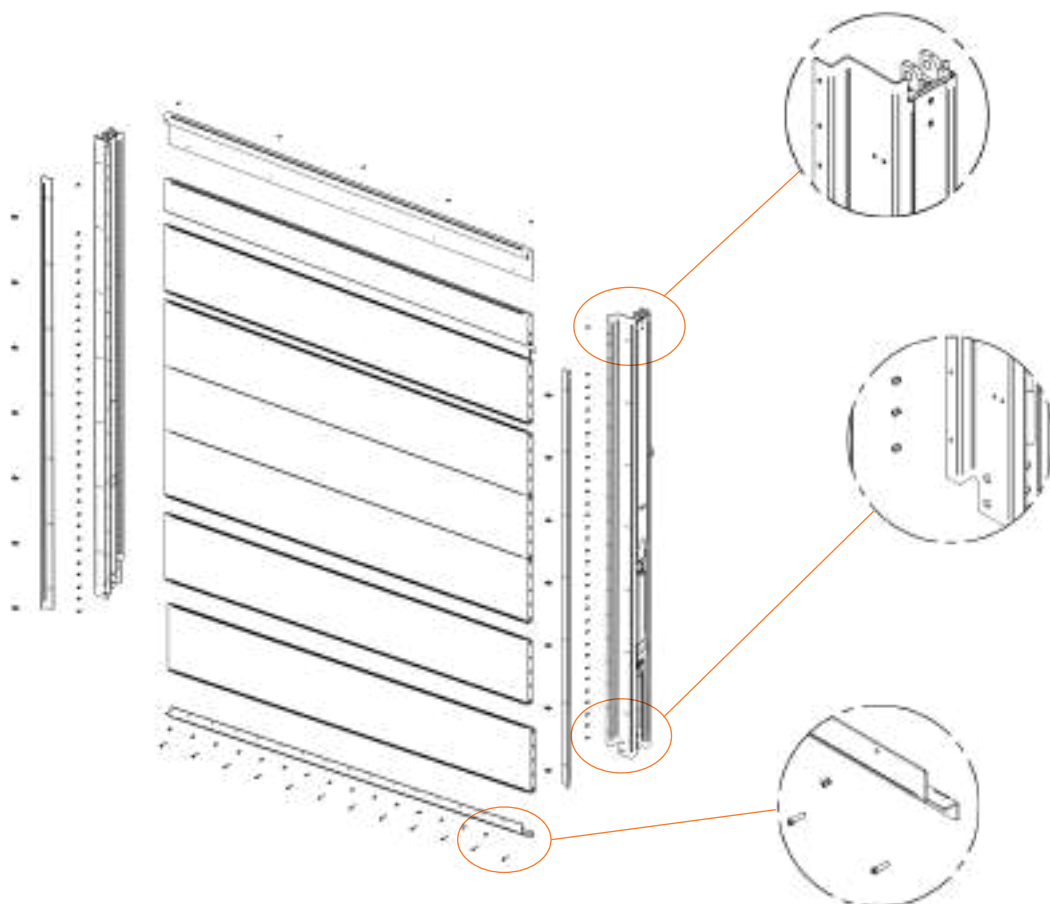

# B-LIFT **TETTO**

## TETTO MAGNUM TOPLINE2

Come tetto standard, B-LIFT utilizza il MAGNUM TOPLINE2, fiore all'occhiello di AUTOCAR e riferimento sul mercato in Europa per i sistemi di tetto scorrevole. Il sistema MAGNUM è stato certificato e testato dai migliori costruttori di veicoli centinati in Europa, che lo scelgono come soluzione standard per i loro veicoli centinati.



## MAGNUM TOPLINE2 ROOF

B-LIFT bodykit features MAGNUM TOPLINE2 as sliding roof. This is the flagship of AUTOCAR products, a European reference for sliding roof solutions. MAGNUM system has been tested and certified by the best trailer manufacturers in Europe who use it as standard sliding roof for their curtain bodies.

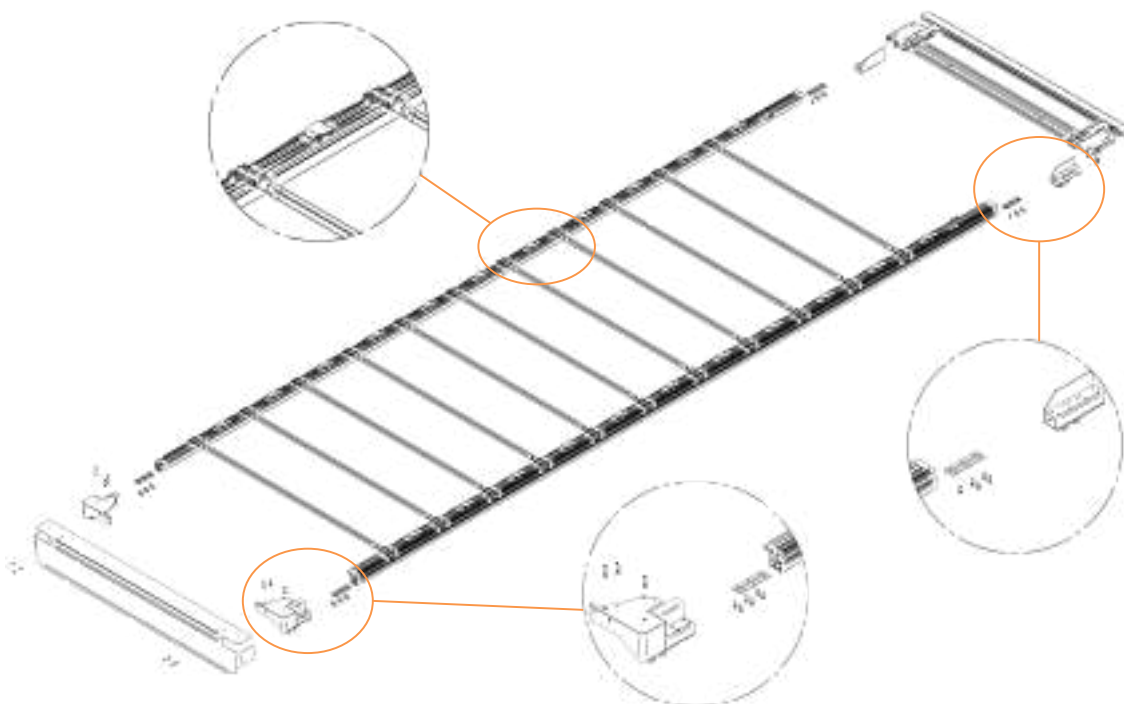

“ Il Tetto MAGNUM TOPLINE2 è ANCORA più leggero ”  
MAGNUM TOPLINE2 roof is EVEN lighter





# B-LIFT ROOF

## PIASTRE SUPPORTO TETTO

Il collegamento del tetto con le piantane anteriori e posteriori avviene tramite delle piastre molto robuste, pre-forate, che assicurano un montaggio semplice e solido. Ogni dettaglio è stato pensato per rendere le operazioni di montaggio il più semplici possibile ma allo stesso tempo con la sicurezza di ottenere una carrozzeria adatta agli impieghi più esigenti.

Il kit B-LIFT è disponibile nella configurazione con trave BILINE o con trave SLIM, per una maggiore altezza di carico interna.



## ROOF CONNECTION BRACKETS

The roof fastening with corner pillars (front and rear) is made using strong pre-holed brackets, which assure a simple and solid assembly. Every detail has been designed in order to make assembly as easy as possible and in order to have a body suitable for the toughest use.

Our B-LIFT kit is available both with BILINE as well as with SLIM beam, that allows higher loading height.

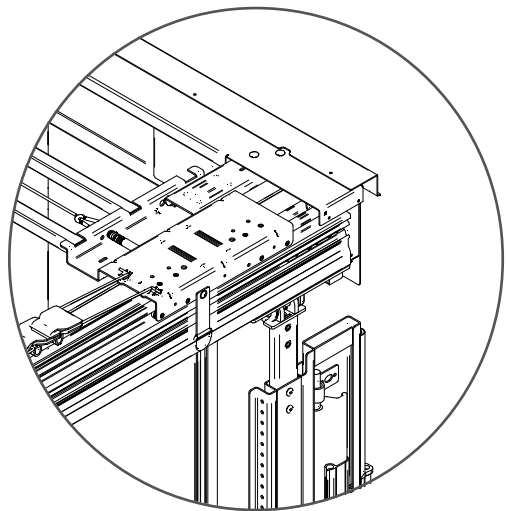

# B-LIFT PIANTANE

## PIANTANE UNIVERSALI

Il kit centina B-LIFT è stato progettato in modo tale da soddisfare tutte le altezze richieste. Realizzate in acciaio alto-resistenziale S500, le piantane B-LIFT vengono consegnate con un'altezza standard, offrendo al carrozziere la possibilità di regolarle all'altezza desiderata. Le nostre piantane possono infatti essere agevolmente tagliate nella parte inferiore, grazie ad appositi segni di taglio, fino al raggiungimento dell'altezza necessaria. Questo permette di avere il nostro kit comodamente in stock, pronto all'uso, senza doverlo ordinare su misura.

Le nostre piantane vengono consegnate con pre-trattamento di cataforesi nera che garantisce protezione dalla ruggine.

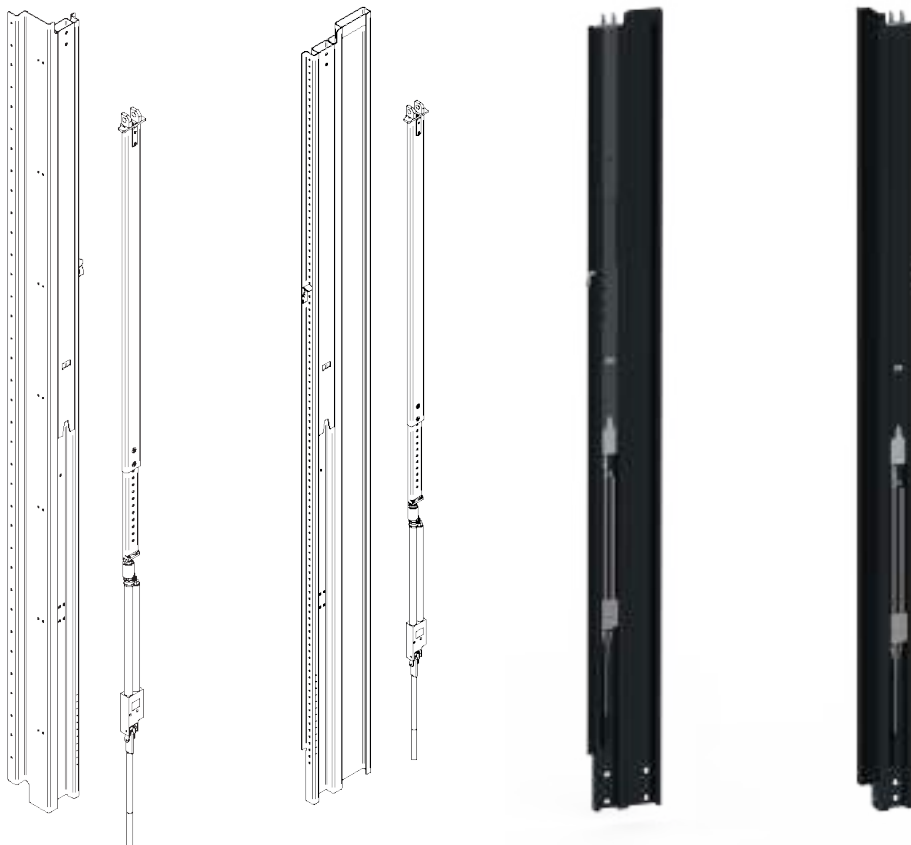



# B-LIFT CORNER PILLARS

## UNIVERSAL PILLARS

Our B-LIFT curtain kit has been designed in order to meet all needs in terms of height. Made of high-strength steel S500, our B-LIFT corner pillars are delivered in a standard height, offering to the bodybuilder the possibility of adjusting them to the desired height. Our corner pillars can be easily cut in the lower part to the desired height, thanks to cut marks. This allows the bodybuilder to keep our bodywork kit in his stock, ready to use, without needing to order it customized. Our corner pillars are pre-treated with black cathaphoresis that protects them from rust.

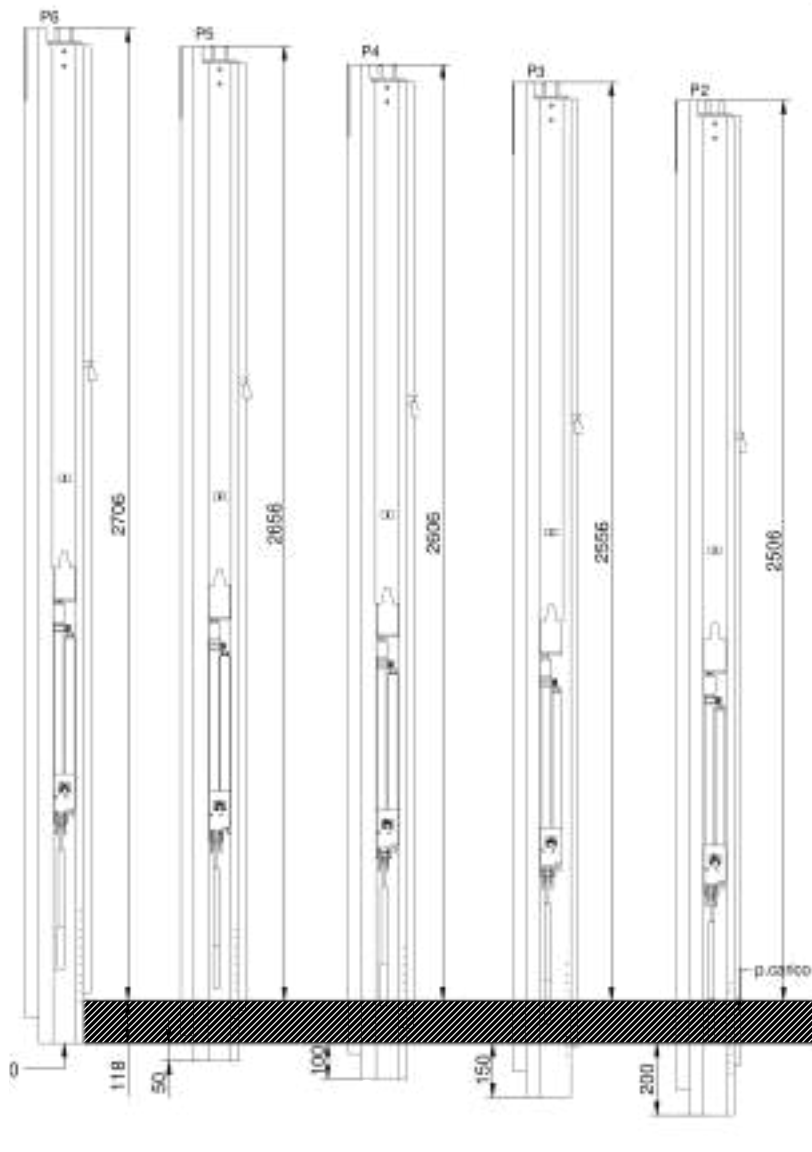



## PIANTANE CON SISTEMA DI SOLLEVAMENTO

La nostra centina B-LIFT è la soluzione ideale per allestire un veicolo telonato medio pesante (7,5-26 ton) con dispositivo alzabassa per sollevamento del tetto nelle operazioni di carico/scarico.

Le piantane B-LIFT, nella parte inferiore, sono predisposte per ospitare una pompa idraulica manuale, in grado di sollevare fino a 575 kg ciascuna.

AUTOCAR ha progettato appositi sfili in acciaio zincato che collegano il tetto alle pompe individuali, consentendone il sollevamento.





## CORNER PILLARS WITH LIFTING MECHANISM

Our B-LINE Bodywork kit is the perfect solution to fully equip a curtain body of medium-heavy weight (7,5 -26 ton) with roof lifting system to ease loading and unloading operations.

B-LIFT corner pillars are designed to mount a hand pump in the lower part, that can lift loads up to 575 kg each.

AUTOCAR designed specific zinc plated sliding elements that connect the roof to the manual pump, allowing the lifting of the roof itself.



# POSTERIORE



# ORTALE

## PORTALE POSTERIORE

Il portale posteriore viene composto da 2 piantane da 40 mm di larghezza realizzate in acciaio alto resistenziale. Le porte MAGNA2 si presentano con solo 3 doghe verticali da 420 mm, con una estetica e robustezza senza paragoni nel settore. È possibile scegliere tra diverse opzioni di chiusura.



Forniamo PORTE in kit, SEMPLICI da assemblare...



We supply DOORS in kit, EASY to assemble...

# REAR FRAME

## REAR FRAME

Rear frame is composed of 2 pillars with 40 mm width and made of high strength steel. Magna2 doors have only 3 vertical profiles which are 420 mm; their design and strength have no comparison in the market. You can select different lock types.

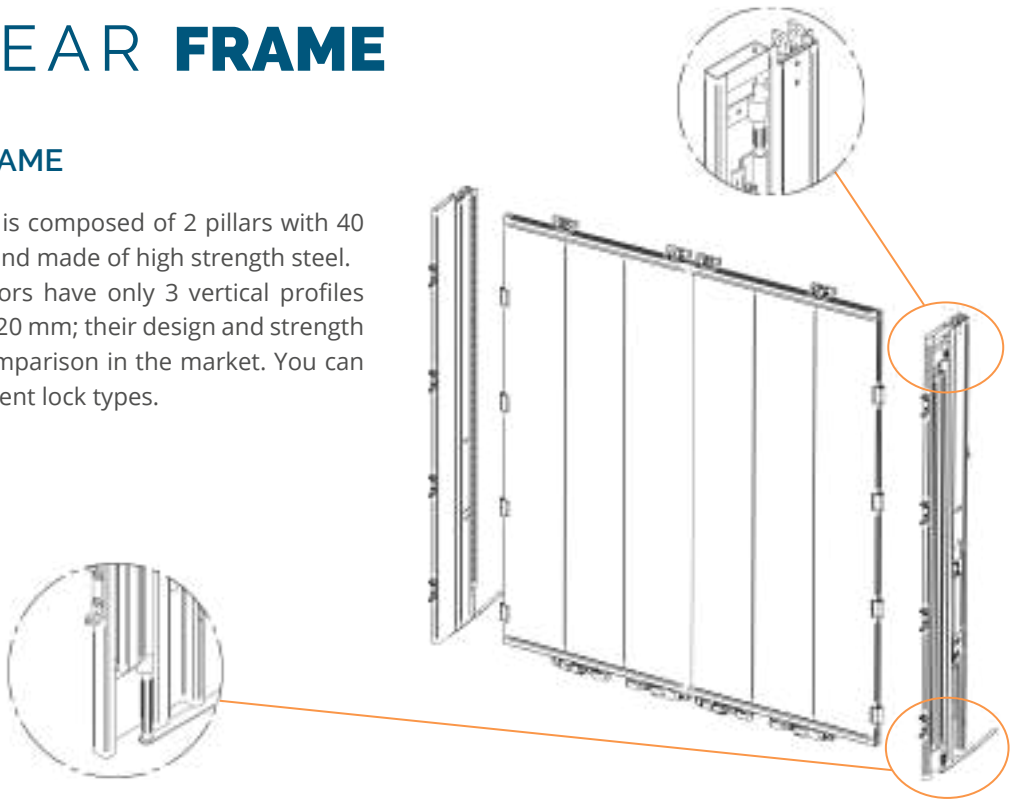

...oppure GIÀ assemblate  
e PRONTE all'uso

...or COMPLETELY assembled  
and READY to use



## GRAFICA PERSONALIZZATA

Le porte montate di Autocar possono essere fornite complete di grafica personalizzata. Grazie alla collaborazione con la ditta Il Telone, siamo in grado di realizzare e applicare adesivi di diverse tipologie che variano dal semplice prespaziato alla stampa digitale (anche intagliata) con laminazione protettiva per decorazione di superfici rigide come le porte posteriori. Possiamo vantare una garanzia di 5 anni per stampe digitali in adesivo con laminazione esterna di protezione.







# CUSTOMIZED GRAPHIC

Autocar rear doors can be supplied complete with customized graphic.  
Thanks to our cooperation with company Il Telone, we can produce and apply different kind of stickers, that vary from simple pre-shaped sticker to digital printing with protective laminate for decorating hard surfaces as rear doors.  
We offer 5 years warranty for digital printing on sticker with protective laminate.





## OPZIONE MULTIPUNTO

Su richiesta è possibile avere il kit centina B-LINE con dispositivo multipunto, per variare l'altezza del veicolo con un passo di 50 mm.

Per la versione multipunto, Autocar ha progettato un particolare sfilo composto da 4 elementi che offrono la regolazione dell'altezza mediante un sistema a ghiera.



**UP TO + 150**





## MULTI-HEIGHT VERSION

Upon request, we can deliver our B-LINE bodywork curtain kit in the multi-height version, that allow to adjust the height of the truck with a distance of 50 mm.

For the multi-height version, Autocar developed a special type of vertical sliding elements composed of 4 pieces that allow the adjustment of the height through a screw-lock mechanism.

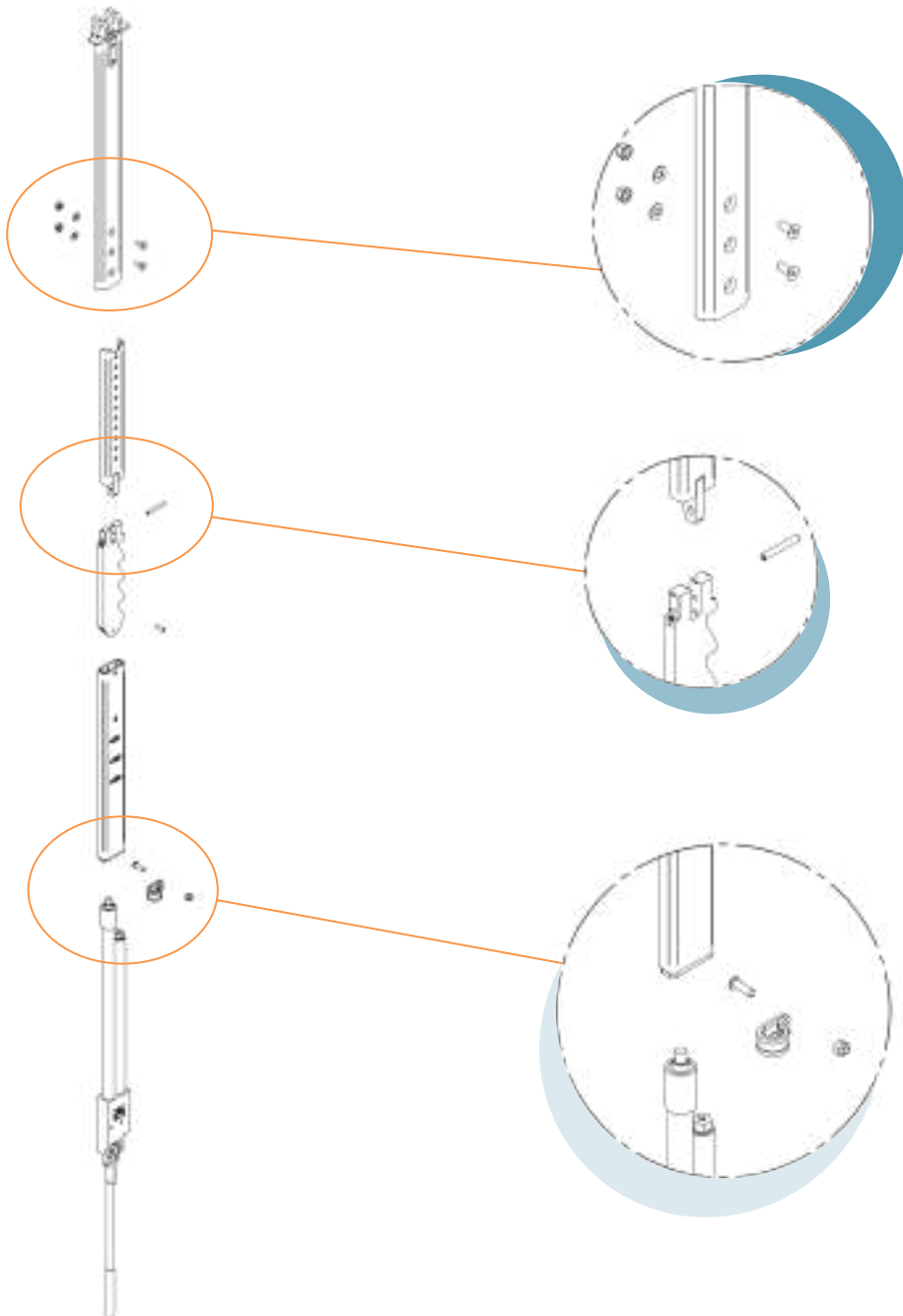



## TRAVERSA MULTIPUNTO

Il tetto Topline2 per B-LIFT con dispositivo multipunto dispone di una particolare traversa, che presenta delle feritoie a 4 altezze fino a raggiungere +150mm. La porta posteriore viene agganciata mediante degli arpioni piatti, progettati appositamente per la traversa multipunto.



## MULTI-HEIGHT CROSSBAR

Our Topline2 sliding roof for multi-height version for B-LIFT multi-height has a special rear crossbar with holes in 4 different heights up to +150mm. The rear door is connected to this crossbar thanks to flat upper keepers, designed specifically for multi-height crossbar.





## CHIAVISTELLO MULTIPUNTO

La piantana è dotato di un chiavistello che permette la regolazione dell'altezza con passo di 50mm, in posizione aperta, permette il normale scorrimento dello sfilo mentre in posizione chiusa, blocca lo sfilo all'altezza definita.

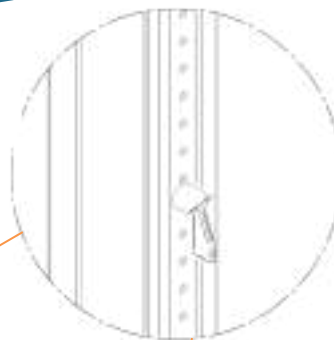

## MULTI-HEIGHT LATCH

Our corner pillar has a latch that allows the adjustment of the height with a distance of 50mm; in open position, it allows the regular sliding of the carriage, while in closed position, it blocks the carriage to the defined height.

# SIDE CURTAIN KIT B-LINE

## KIT CENTINA B-LINE

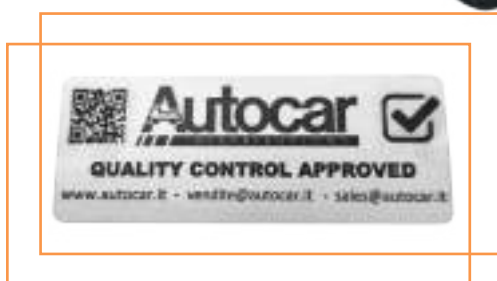

### MATERIALI DI ALTA QUALITÀ

B-LIFT è un kit di componenti di alta qualità. I materiali sono stati selezionati dai nostri ingegneri per ottimizzare la resistenza, la durabilità e il peso. Questo comporta leghe di alluminio con alto trattamento termico e acciaio alto resistenziale (S500 e S700). L'impiego di questi materiali garantisce agli utilizzatori la funzionalità dell'allestimento anche nelle condizioni più esigenti.



S  
5  
0  
0  
&  
S  
7  
0  
0

## HIGH QUALITY MATERIALS

B-LIFT is a high quality curtain kit. Materials have been selected by our engineers in order to optimise resistance, durability and weight. This fact implies the use of aluminium alloys with high thermic treatment and high strength steel (S500 and S700). The use of these materials can guarantee end users the functionality of the curtain body even in the hardest conditions.

# PIANTONI **MAXI**

## PERSONALIZZAZIONE

La centina B-LIFT in kit può essere personalizzata a seconda dell'utilizzo del mezzo. Senza dover cambiare i componenti principali, può essere consegnata con piantoni centrali MAXI3 per veicolo side curtain, realizzati in acciaio alto resistenziale oppure a 2 leve MAXI DUO per veicolo spondato. Sono anche disponibili tutti gli accessori necessari per i teli laterali, profili e cricchetti di tensionamento laterale, profili di aggancio telo, stecche di alluminio ecc.

## CUSTOMIZATION

B-LIFT bodywork can be customized according to its final use. Without changing main parts in the system, the kit can be delivered with central pillars for side curtain MAXI3 or with 2 levers pillars for sideboards MAXI DUO. Tensioning profiles, ratchets, aluminium sideboards and other accessories are also available upon request.





### PIANTONI CENTRALI SCORREVOLI MAXI3

Il piantone scorrevole MAXI3 di AUTOCAR è perfetto come piantone centrale per veicoli centinati, con o senza sistema di sollevamento. I nostri piantoni si distinguono per la loro robustezza, che garantisce la massima sicurezza durante il trasporto, per la loro leggerezza ed estrema facilità di apertura, che consente di accedere rapidamente al piano di carico.

Su richiesta è possibile fornire piantoni centrali MAXI3 multipunto sia per veicoli side curtain, sia per veicoli spondati, grazie alle chiusure in alluminio HEAVY DUTY, e alle apposite tasche laterali.



### SLIDING CENTRAL PILLARS MAXI3

The sliding pillar MAXI3 is used as a central pillar for curtainsiders, with or without lifting system.

The main characteristic of our pillars is strength, that assures the best safety conditions during transport; our pillars are light and easy to open, in order to allow a quick access to the loading platform.

Upon request, we can also supply sliding central pillars MAXI3 in the multi-height version for both curtainsider and trucks with sideboards, thanks to HEAVY DUTY aluminum locks and specific side lower pockets.





# PARAMETRICO

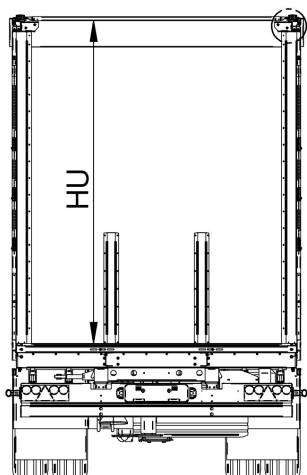

A-A

## LEGENDA / KEY

- HU: Altezza interna utile / internal height
- P= Parametrico / height references

HU  
2612

HU  
2662

HU  
2712

P1

P2

P3





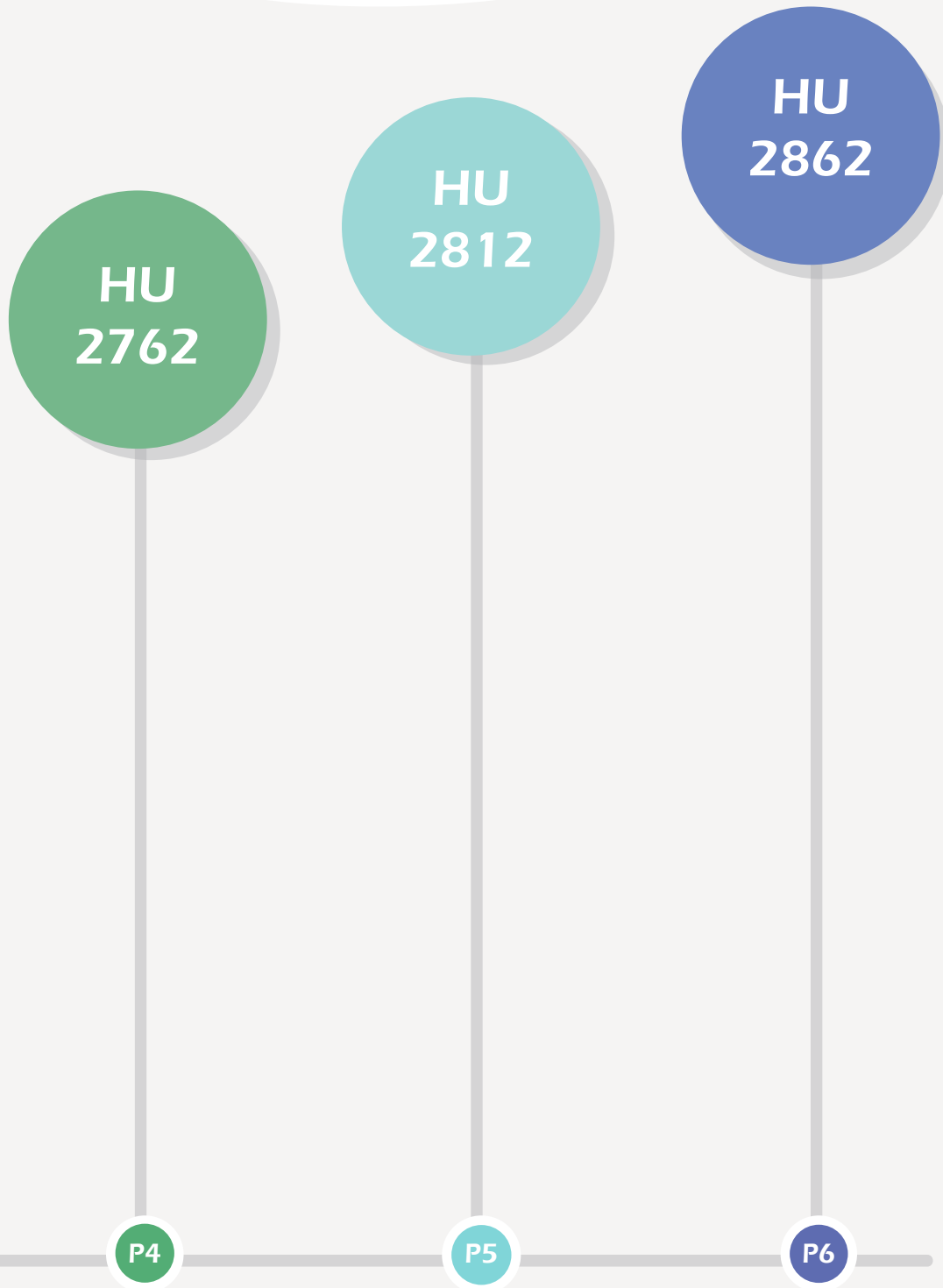















# HEIGHT REFERENCES



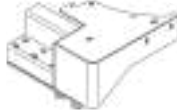

La centina B-LIFT in kit con trave QUADRA

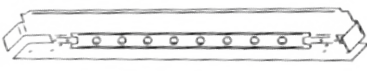

1X  Anteriore DX A07M1000016C	1X  Anteriore SX A07M1000021C	1X  Posteriore DX A07M3000039C	1X  Posteriore SX A07M3000044C	2X  A07M1000030ZN	4X  A07M3000083ZN	4X  A07M3000085ZN	6X  A07M3000070ZN
							8X  A07M3000021ZN
							4X  A07S3000065ZN
1X  SX A07S3000081ZN	1X  DX A07S3000080ZN	1X  DX A07S3000078ZN	1X  SX A07S3000079ZN				8X  A07S3000109ZN
1X  T2000063C	1X  A07P1000013ZN						
1X  A07P1000012ZN	1X  A07T2000031ZN						



B-LIFT bodywork curtain kit with SQUARE rail











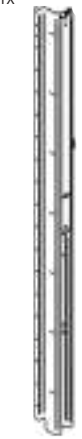







# B-LIFT SLIM

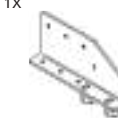
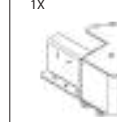
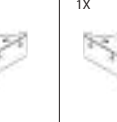

La centina B-LIFT in kit con trave a "L"

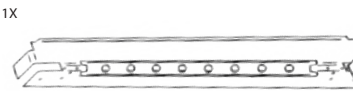

1X  Anteriore DX A07M1000016C	1X  Anteriore SX A07M1000021C	1X  Posteriore DX A07M3000039C	1X  Posteriore SX A07M3000044C	2X  A07M1000030ZN	4X  A07M3000083ZN	4X  A07M3000085ZN	6X  A07M3000070ZN
							8X  A07M3000021ZN
1X  SX S3000149ZN	1X  DX S3000148ZN	1X  DX S3000140ZN	1X  SX S3000141ZN	8X  60376	4X  A07S3000065ZN		
1X  T2000063C		1X  A07P1000013ZN					
1X  A07P1000012ZN		1X  A07T2000031ZN					



B-LIFT bodywork curtain kit with "L" rail





# B-LIFT SLIM MULTI



La centina B-LIFT in kit con opzione MULTIPUNTO



1X  Anteriore DX A07M1000016C	1X  Anteriore SX A07M1000021C	1X  Posteriore DX A07M3000039C	1X  Posteriore SX A07M3000044C	2X  A07M1000030ZN	4X  A07M3000027ZN	4X  A07M3000026ZN	4X  A07M3000028ZN
						4X  P2000002ZN	
						4X  A07M3000025ZN	4X  A07S3000065ZN
1X  S3000144ZN	1X  DX S3000145ZN	1X  DX S3000140ZN	1X  SX S3000141ZN	8X  60376	6X  A07M3000070ZN		
8X  A07M3000021ZN	1X  A07T2000031ZN	1X  A07P1000013ZN	4X  60031				
1X  T2000063C	1X  A07P1000012ZN	1X  T2000058C					



B-LIFT bodywork curtain kit  
with MULTI-HEIGHT mechanism



Forniamo TUTTO il necessario per un FACILE assemblaggio



We deliver ALL the necessary components for an EASY assembling

# NOTE



A series of 20 horizontal blue lines, evenly spaced, providing a template for writing notes.





Via Luigi Abbiati 3/5, 25125 Brescia (BS) Italy - Tel. +39.030.9178960

[www.autocar.it](http://www.autocar.it) - E-mail: [sales@autocar.it](mailto:sales@autocar.it) - [vendite@autocar.it](mailto:vendite@autocar.it)